

Thermostats Type RT

Description



A thermostat is a temperature-controlled switch. The position of the contacts depends on the temperature of the sensor and the set scale value.

The RT series covers thermostats for general industrial and marine applications, including differential thermostats with room sensors, duct sensors, and capillary tube sensors

Contents

	Page
Description	1
Survey of types, temperature ranges.....	2
Technical data and code nos. all types	3
Nomograms	5
Technical data.....	7
Approvals	7
Dimensions and weight.....	8
Choice of suitable sensor pocket.....	8
Installation, setting	9
Function.....	10
Types of charge	11
Thermostat for control of ventilation plant	12
Thermostats with adjustable neutral zone	13
Differential thermostats.....	14
Spare parts and accessories	15

Thermostats type RT

-50	0	50	100	150	200	250	300°C	Range p _e bar	Type
Thermostats with cylindrical remote sensor								-60 → -25	RT 10
Thermostats with cylindrical remote sensor								-45 → -15	RT 9
Thermostats with cylindrical remote sensor								-30 → 0	RT 13
Thermostats with cylindrical remote sensor								-25 → 15	RT 3,2,7
Thermostats with cylindrical remote sensor								-20 → 12	RT 8
Thermostats with cylindrical remote sensor								-5 → 10	RT 12
Thermostats with cylindrical remote sensor								-5 → 30	RT 14
Thermostats with cylindrical remote sensor								-5 → 50	RT 26
Thermostats with cylindrical remote sensor								5 → 22	RT 23
Thermostats with cylindrical remote sensor								8 → 32	RT 15
Thermostats with cylindrical remote sensor								25 → 90	RT 101
Thermostats with cylindrical remote sensor								20 → 90	RT 106
Thermostats with cylindrical remote sensor								30 → 140	RT 108
Thermostats with cylindrical remote sensor								70 → 150	RT 107
Thermostats with cylindrical remote sensor								120 → 215	RT 120
Thermostats with cylindrical remote sensor								150 → 250	RT 123
Thermostats with cylindrical remote sensor								200 → 300	RT 124
Thermostats with room sensors, duct sensor and capillary tube sensor								-50 → -15	RT 17
Thermostats with room sensors, duct sensor and capillary tube sensor								-30 → 0	RT 11
Thermostats with room sensors, duct sensor and capillary tube sensor								-25 → 15	RT 34
Thermostats with room sensors, duct sensor and capillary tube sensor								-5 → 30	RT 4
Thermostats with room sensors, duct sensor and capillary tube sensor								10 → 35	RT 115
Thermostats with room sensors, duct sensor and capillary tube sensor								10 → 45	RT 103
Thermostats with room sensors, duct sensor and capillary tube sensor								15 → 45	RT 140
Thermostats with room sensors, duct sensor and capillary tube sensor								40 → 80	RT 141
Thermostats with room sensors, duct sensor and capillary tube sensor								25 → 90	RT 102
Thermostats with adjustable neutral zone								-20 → 12	RT 8L
Thermostats with adjustable neutral zone								-5 → 30	RT 14L
Thermostats with adjustable neutral zone								0 → 38	RT 16L
Thermostats with adjustable neutral zone								15 → 45	RT 140 L
Thermostats with adjustable neutral zone								25 → 90	RT 101L
Differential thermostats								0 → 15	RT 270
Differential thermostats								0 → 20	RT 271

Technical data and code nos. When ordering, please state type and code number.

- Types of charge
 A: Vapour charge - sensor must not be the warmest part.
 B: Adsorption charge
 C: Partial charge - the sensor must not be the coldest part



RT 107 with cylindrical remote sensor, cover with windows and hand setting knob



RT 106 with cylindrical remote sensor, cover with windows and hand setting knob

Thermostats with cylindrical remote sensor

Preferred charge

Setting range °C	Adjustable differential range*)		Max. sensor temperature °C	Type of charge	Capillary tube length m	Code no.			Type
	At lowest range setting °C	At highest range setting °C							
-60 → -25	1.7 → 7	1 → 3	150	A	2	017-507766			RT 10
-45 → -15	2.2 → 10	1 → 4.5	150	A	2	017-506666			RT 9
-30 → 0	1.5 → 6	1 → 3	150	A	2	017-509766			RT 13
-25 → 15	2.8 → 10	1 → 4	150	A	2	017-501466			RT 3
-25 → 15	2.8 → 10	1 → 4	150	A	5	017-501666			RT 3
-25 → 15	2.8 → 10	1 → 4	150	A	8	017-501766			RT 3
-25 → 15	5 → 18	6 → 20	150	B	2	017-500866			RT 2
-25 → 15	2 → 10	2.5 → 14	150	B	2	017-505366			RT 7
-25 → 15	2 → 10	2.5 → 14	150	B	5	017-505566			RT 7
-25 → 15	2 → 10	2.5 → 14	150	B	8	017-505666			RT 7
-20 → 12	1.5 → 7	1.5 → 7	145	B	2	017-506366			RT 8
-5 → 10	1 → 3.5	1 → 3	65	B	2	017-508966			RT 12
-5 → 30	2 → 8	2 → 10	150	B	2	017-509966			RT 14
-5 → 30	2 → 8	2 → 10	150	B	3	017-510066			RT 14
-5 → 30	2 → 8	2 → 10	150	B	5	017-510166			RT 14
-5 → 30	2 → 8	2 → 10	150	B	8	017-510266			RT 14
-5 → 30	2 → 8	2 → 10	150	B	10	017-510366			RT 14
-5 → 50	2 → 9	3 → 19	150	B	2	017-518066			RT 26
5 → 22	1.1 → 3	1 → 3	85	B	2	017-527866			RT 23
8 → 32	1.6 → 8	1.6 → 8	150	B	2	017-511566			RT 15
25 → 90	2.4 → 10	3.5 → 20	300	B	2	017-500366	017-500466	017-500566	RT 101
25 → 90	2.4 → 10	3.5 → 20	300	B	3	017-500666			RT 101
25 → 90	2.4 → 10	3.5 → 20	300	B	5	017-502266	017-502366		RT 101
25 → 90	2.4 → 10	3.5 → 20	300	B	8	017-502466			RT 101
25 → 90	2.4 → 10	3.5 → 20	300	B	10	017-502566			RT 101
20 → 90	4 → 20	2 → 7	120	C	2	017-504866		017-504966	RT 106
20 → 90	4 → 20	2 → 7	120	C	3			017-505166	RT 106
20 → 90	4 → 20	2 → 7	120	C	5	017-505066			RT 106
30 → 140	5 → 20	4 → 14	220	B	2	017-506066			RT 108
70 → 150	6 → 25	1.8 → 8	215	C	2	017-513566	017-513666	017-513766	RT 107
70 → 150	6 → 25	1.8 → 8	215	C	3	017-513966			RT 107
70 → 150	6 → 25	1.8 → 8	215	C	5	017-514066	017-514166	017-514366	RT 107
70 → 150	6 → 25	1.8 → 8	215	C	8	017-514466			RT 107
70 → 150	6 → 25	1.8 → 8	215	C	10	017-514566			RT 107
120 → 215	7 → 30	1.8 → 9	260	C	2	017-520566 ¹⁾	017-521166 ¹⁾		RT 120
120 → 215	7 → 30	1.8 → 9	260	C	5	017-520666 ¹⁾			RT 120
120 → 215	7 → 30	1.8 → 9	260	C	8	017-520766 ¹⁾			RT 120
120 → 215	7 → 30	1.8 → 9	260	C	2	017-520866	017-521466 ²⁾		RT 120
120 → 215	7 → 30	1.8 → 9	260	C	5	017-520966			RT 120
150 → 250	6.5 → 30	1.8 → 9	300	C	2	017-522066	017-522466		RT 123
150 → 250	6.5 → 30	1.8 → 9	300	C	5	017-522266			RT 123
200 → 300	5 → 25	2.5 → 10	350	C	2	017-522766	017-523166		RT 124
200 → 300	5 → 25	2.5 → 10	350	C	5	017-522966			RT 124

*) See also pages 5-6
¹⁾ Thermostats fitted with neon lamp connected to terminal 4
²⁾ Thermostat with tamper-proof seal cap

Thermostats with room sensor, duct sensor and capillary tube sensor

Preferred versions



Thermostat type RT 115 with room sensor



Thermostat type RT 140 with duct sensor



Neutral zone thermostat type RT 16L with room sensor



Differential thermostat type RT 270

Setting range °C	Adjustable differential range*)		Max. sensor temperature °C	Type of charge	Capillary tube length m	Sensor type**) Figur	Code no.	Type
	At lowest range setting °C	At highest range setting °C						
-50 → -15	2.2 → 7	1.5 → 5	100	A	-	1	017-511766	RT 17
-30 → 0	1.5 → 6	1 → 3	66	A	-	1	017-508366	RT 11
-25 → 15	2 → 10	2 → 12	100	B	-	1	017-511866	RT 34
-5 → 30	1.5 → 7	1.2 → 4	75	A	-	1	017-503666	RT 4
-5 → 30	1.5 → 7	1.2 → 4	75	A	-	1	017-503766¹⁾	RT 4
10 → 35	⁵⁾	⁵⁾	92	B	-	1	017-519766²⁾	RT 115
10 → 35	⁵⁾	⁵⁾	92	B	-	1	017-519866³⁾	RT 115
10 → 45	1.3 → 7	1 → 5	100	A	-	1	017-515566	RT 103
15 → 45	1.8 → 8	2.5 → 11	240	B	2	2	017-523666	RT 140
40 → 80	1.9 → 9	2.5 → 17	250	B	2	2	017-524166	RT 141
25 → 90	2.4 → 10	3.5 → 20	300	B	2	3	017-514766	RT 102

*) See also pages 5-6

**) See also fig. 1-5

¹⁾ Bellows with built-in heating element which reduces the thermal differential (220V)

²⁾ Can be connected to 220 V and 380 V

³⁾ Can be connected to 220 V

⁵⁾ Special thermostat for ventilation plant

Thermostats with adjustable neutral zone

Setting range °C	Mechanical differential °C	Adjustable differential range*)		Max. sensor temperature °C	Type of charge	Capillary tube length m	Sensor type**) Figur	Code no.	Type
		At lowest range setting °C	At highest range setting °C						
-20 → -12	1.5	1.5 → 4.4	1.5 → 4.9	145	B	2	4	017L003066	RT 8L
-5 → 30	1.5	1.5 → 5	1.5 → 5	150	B	2	4	017L003466	RT 14L
0 → 38	1.5 / 0.7	1.5 → 5	0.7 → 1.9	100	A	-	1	017L002466	RT 16L
15 → 45	1.8 / 2	1.8 → 4.5	2 → 5	240	B	2	2	017L003166	RT 140L
25 → 90	2.5 / 3.5	2.5 → 7	3.5 → 12.5	300	b	2	4	017L006266¹⁾	RT 101L

*) See fig. 1-5

Differential thermostats

Setting range °C	Mechanical differential °C	Operating range (LT element) °C	Max. sensor temperature °C	Type of charge	Capillary tube length m	Sensor type**) Figur	Code no.	Type
0 → 20	3	20 → 100	200	B	2 × 10	5	017D004466	RT 271
0 → 15	2	-30 → 40	65	B	2 × 5	5	017D003166	RT 270

*) See fig. 1-5

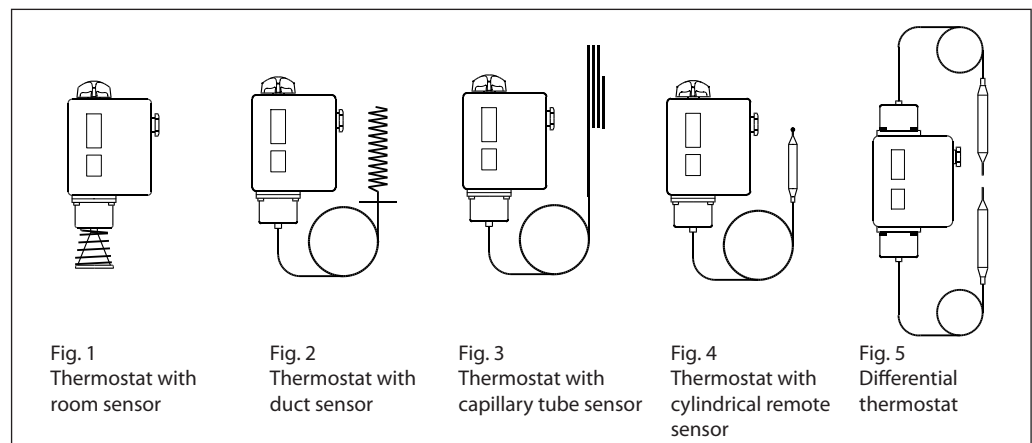

Fig. 1
Thermostat with room sensor

Fig. 2
Thermostat with duct sensor

Fig. 3
Thermostat with capillary tube sensor

Fig. 4
Thermostat with cylindrical remote sensor

Fig. 5
Differential thermostat

Nomograms for obtained differentials

A = Range setting
 B = Obtained differential
 C = Differential setting

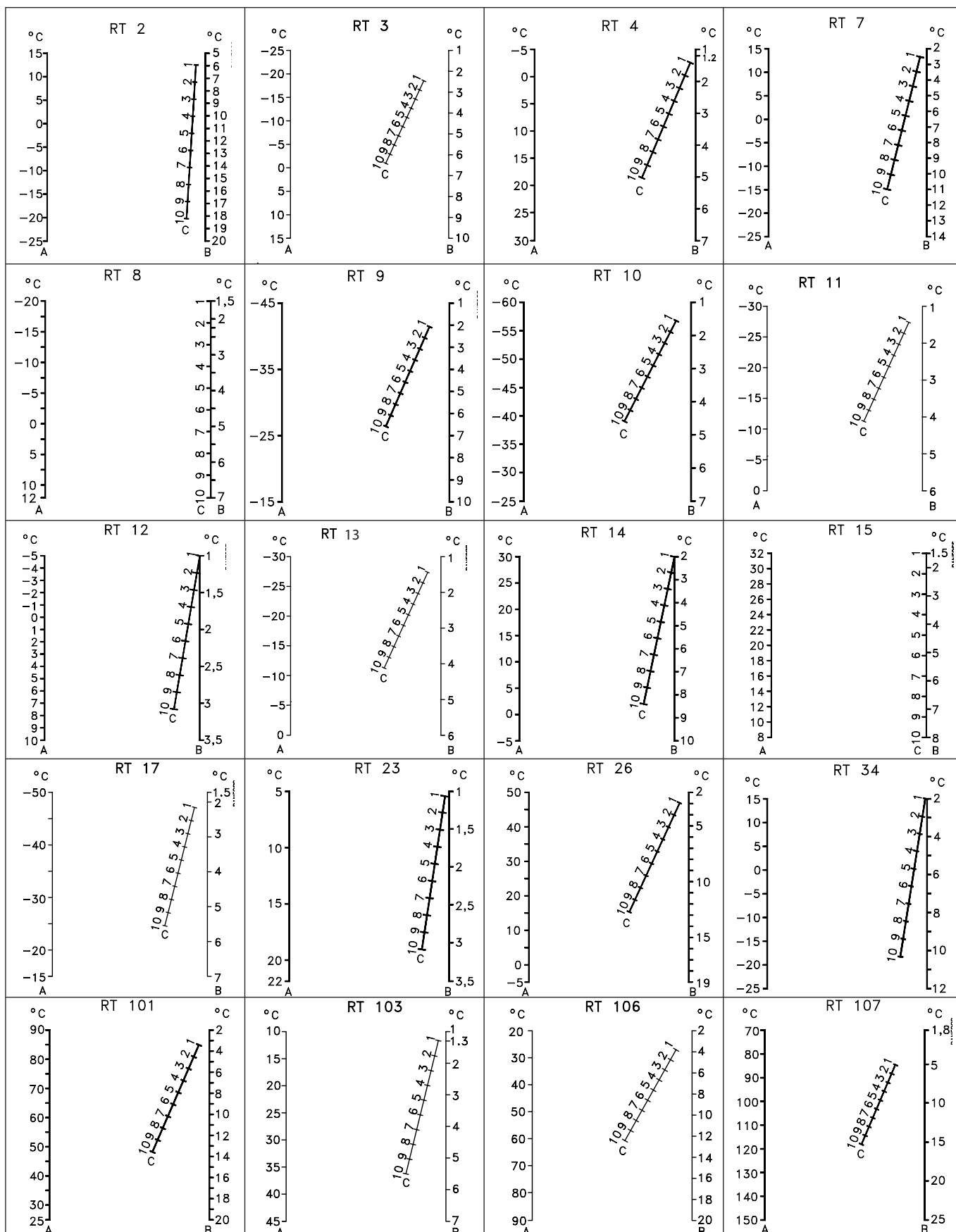

Nomograms for obtained differentials

A = Range setting
 B = Obtained differential
 C = Differential setting

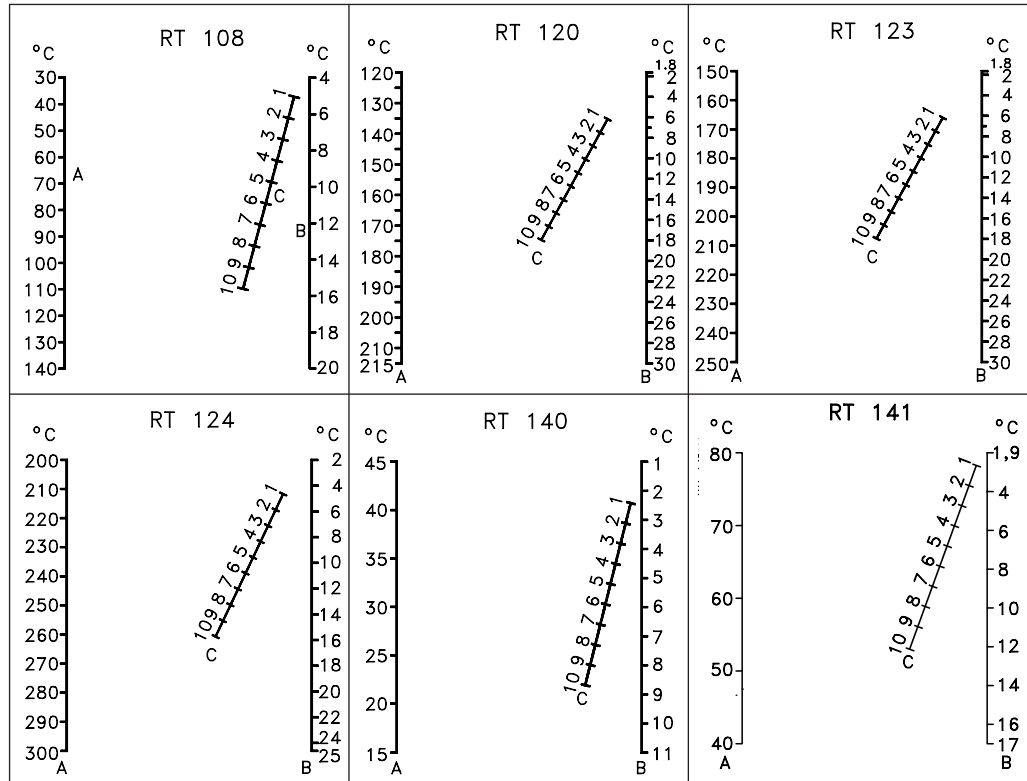

Technical data

Designation	RT thermostats
Ambient temperature	-50 to 70°C . See remarks on charge types page 11
Contact system	<p>SPDT</p> <p>Line</p> <p>DANFOSS A60-969.10</p> <p>Single-pole changeover switch (SPDT)</p>
Contact load	<p>Alternating current: AC-1: 10A, 400 V AC-3: 4A, 400 V AC-15: 3A, 400 V</p> <p>Direct current: DC-13: 12 W, 230 V (see fig. 6)</p>
Contact material:	AgCdO
Special contact system	See "accessories" pages 15-16
Cable entry	2 PG 13.5 for 6 - 14 mm diameter cables
Enclosure	IP 66 acc. to IEC 529 and EN 60529. Units supplied with external reset. IP 54. The thermostat housing is made of bakelite acc. to DIN 53470 Cover is made of polyamide.

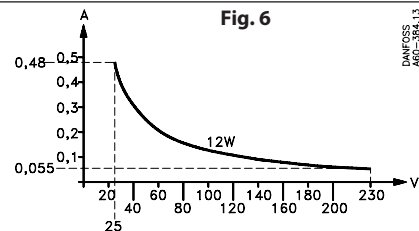

Approvals

RT 2	RT 4	RT 3	RT 12	RT 16	RT 34	RT 101	RT 106	RT 120	RT 124	Approvals
RT 23	RT 10	RT 7	RT 13	RT 102	RT 103		RT 107			
RT 26	RT 11	RT 8	RT 14	RT 141	RT 115		RT 123			
RT 108	RT 16L	RT 8L	RT 14L	RT 271	RT 140					
	RT 17	RT 9	RT 15	RT 270						
	RT 140L									
x	x	x	x	x	x	x	x	x	x	CE marked acc. to EN 60947-4/-5
						x	x	x	x	Det Norske Veritas, Norway
x	x	x	x	x	x	x	x	x	x	CCC, China Compulsory Certificate
							x			Lloyds Register of Shipping, UK
		x	x			x	x	x		Germanischer Lloyd, Germany
						x				Bureau Veritas, France
x	x	x	x	x	x	x	x	x	x	Registro Italiano Navale, Italy
x	x	x	x	x	x	x	x	x	x	RMRS, Russian Maritime Register of shipping
x		x	x			x	x	x	x	Nippon Kaiji Kyokai, Japan

Note: In addition we refer to the certificates, the copies of which can be ordered from Danfoss.
GL approval is conditional on the use of a ship's cable entry

Identification

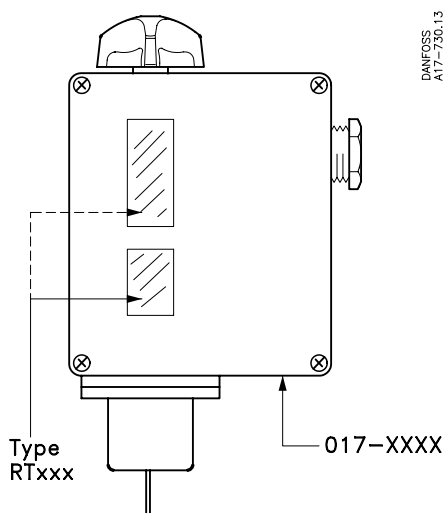

The type designation of the units is given on the setting scale. The code no. is stamped on the bottom of the thermostat housing

Dimensions and weight

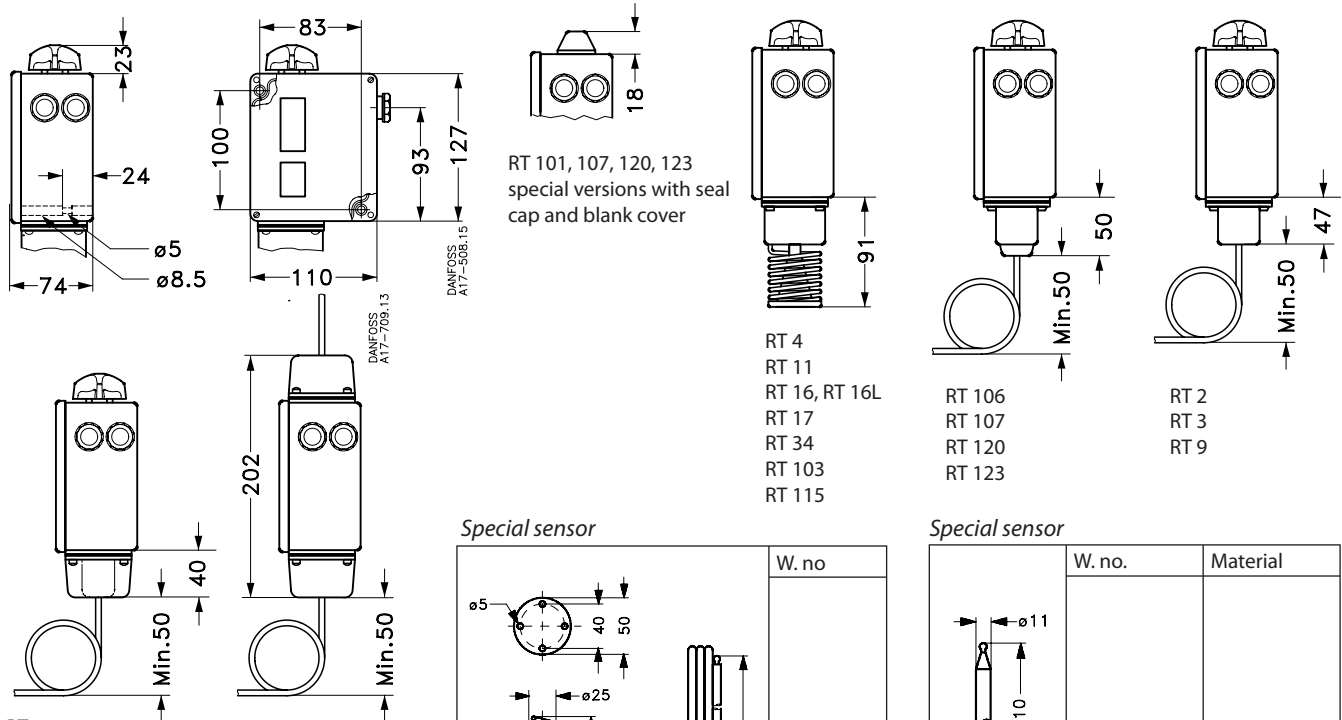

RT 101, 107, 120, 123 special versions with seal cap and blank cover

- RT 4
- RT 11
- RT 16, RT 16L
- RT 17
- RT 34
- RT 103
- RT 115

- RT 106
- RT 107
- RT 120
- RT 123

- RT 2
- RT 3
- RT 9

- RT 7
- RT 8, RT 8L
- RT 10
- RT 12
- RT 13
- RT 14, RT 14L
- RT 15
- RT 21
- RT 23
- RT 24
- RT 26
- RT 101, RT 101L
- RT 108
- RT 124
- RT 140, RT 140L

Weight approx. 1 kg

Special sensor

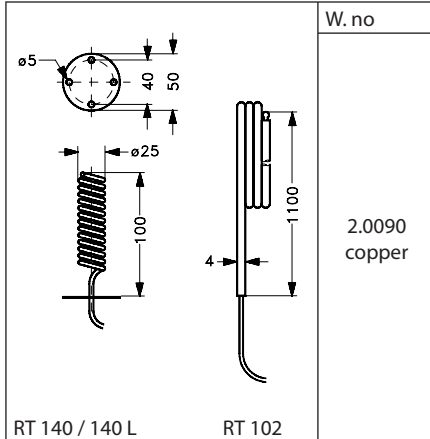

Special sensor

	W. no.	Material
	1.4301	18/8 steel

Choice of suitable sensor pocket

	W. no.	Type	Capillary tube length m	L mm	Suitable sensor pocket Code no.	Material	W.no	L	a ₁	d						
								mm	mm	mm						
	2.0090 copper	RT2/3/7/9 10/13/26/120	2, 3, 5 8, 10	80	017-437066 017-436966	Brass 18/8 steel	2.0321 1.4301	112	G ½	11						
								112	G ½	11						
		RT8/8L/14/ 14L/15/107/123, 270	2, 3, 5, 8, 10	110	017-437966 017-436966	Brass 18/8 steel	2.0321 1.4301	112	G ½	11						
								182	G ½	11						
		RT 101	5, 8, 10	110	017-437066 017-436966	Brass 18/8 steel	2.0321 1.4301	112	G ½	11						
								465	G ½	11						
								RT 14	10	150	017-436766	Brass	2.0321	110	G ½	15
														160	G ½	15
RT 271	10	180	017-421666	Brass	2.0321	110	G ½	15								
						160	G ½	15								
RT 12/13	2	210	017-421666	Brass	2.0321	110	G ½	15								
						160	G ½	15								
RT 108	2	410	017-421666	Brass	2.0321	110	G ½	15								
						160	G ½	15								
	2.0240 brass	RT 106	2.3	76	060L333066 060L332766	Brass	2.0235	110	G ½	15						
								5	86	060L333166 060L332966	18/8 steel	1.4301	110	G ½	15	
													110	G ½	15	
			5	86	060L333066 060L332766	Brass	2.0235	110	G ½	15						
								160	G ½	15						
			5	86	060L333166 060L332966	18/8 steel	1.4301	110	G ½	15						
160	G ½	15														
Sensor pocket, solid version, internal diameter 13.1 mm								108	G ½	15.7						

Installation

RT units have two fixing holes which become accessible when the front cover is removed. Units fitted with switch 017-0181*) must be installed with the setting knob upwards. The other thermostats in the RT series can be installed in any position, except that on plant subjected to severe vibrations it is advantageous to have the screwed cable entry downwards. *) Contact system with snap-action function. See spare parts and accessories, page 15.

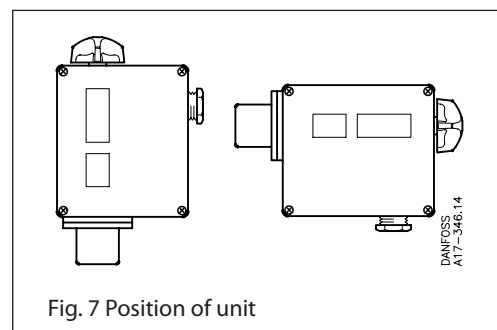
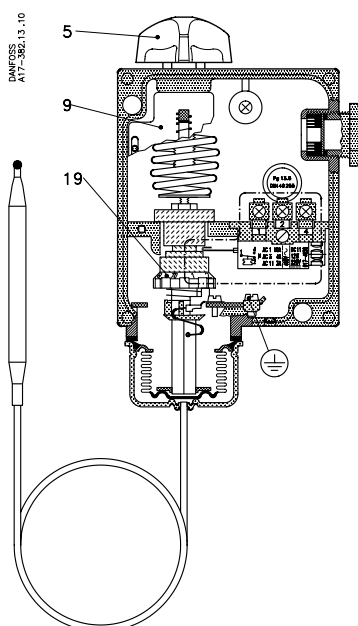

Fig. 7 Position of unit



- 5. Setting knob
- 9. Main scale
- 19. Differential setting disc

The range is set by using the setting knob (5) while at the same time reading the main scale (9). Tools must be used to set thermostats fitted with a seal cap. The differential is set by the differential disc (19).

The size of the obtained differential can be established by comparing the set main scale value and the scale value on the differential disc, with the help of the nomogram for the thermostat concerned (see pages 18-19)

Example
Unit: RT 120
Range setting: 160°C
Differential setting: 2

It will be seen on the nomogram on page 19 that by drawing a line from 160°C on scale A, through 2 on scale C, the value for the differential can be read from scale B: 6°C.

Selection of differential (mechanical differential)
To ensure that the plant functions properly, a suitable differential is necessary. Too small a differential will give rise to short running periods with a risk of hunting. Too high a differential will result in large temperature variations.

Differentials

The mechanical differential is the differential that is set on the differential disc in the thermostat. The thermal differential (operating differential) is the differential the system operates on. The thermal differential is always greater than the mechanical differential and depends on three factors:

- 1) flow velocity of the medium
- 2) temperature charge rate of the medium and
- 3) heat transmission

The medium

The fastest reaction is obtained from a medium having high specific heat and high thermal conductivity. It is therefore advantageous to choose a medium that fulfills these conditions (provided there is a choice). The flow velocity of the medium is also of significance. (Optimum flow velocity for liquids is approx. 0.3 m/s).

Example:

Regulation of a central heating boiler
The temperature in an oil-fired central heating boiler must be regulated by an RT 101. Max. temperature 76°C. Min. temperature 70°C. Differential 76-70 = 6°C.

1. Connect the oil burner via thermostat terminals 1-2.
2. Set the thermostat on 70°C using the hand knob (5), fig. 8.
3. Set the differential disc (19) on 3. This figure is obtained from the RT 101 nomogram, page 5.

When the plant has been operating for some time an assessment can be made of whether the thermal differential is satisfactory. If it is too large, reduce the mechanical differential of the thermostat.

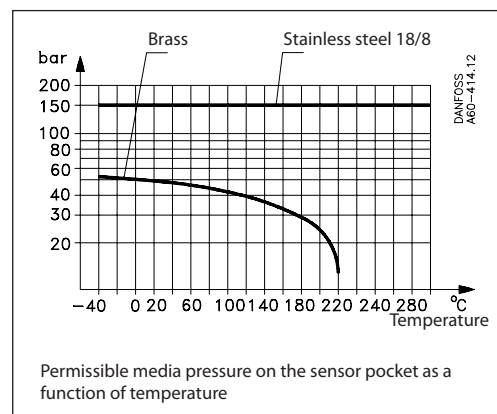

Function

a. RT thermostats with automatic reset
 The RT thermostats are set according to the function required on falling temperature. Contacts 1-4 break while contacts 1-2 make when the temperature falls to the scale setting. The contacts changeover to their initial position when the temperature again rises to the scale setting plus the differential (see fig. 9).

Contact function

- I. Contact changeover for rising temperature occurs at scale setting plus differential..
- II. Contact changeover for falling temperature occurs at scale setting.

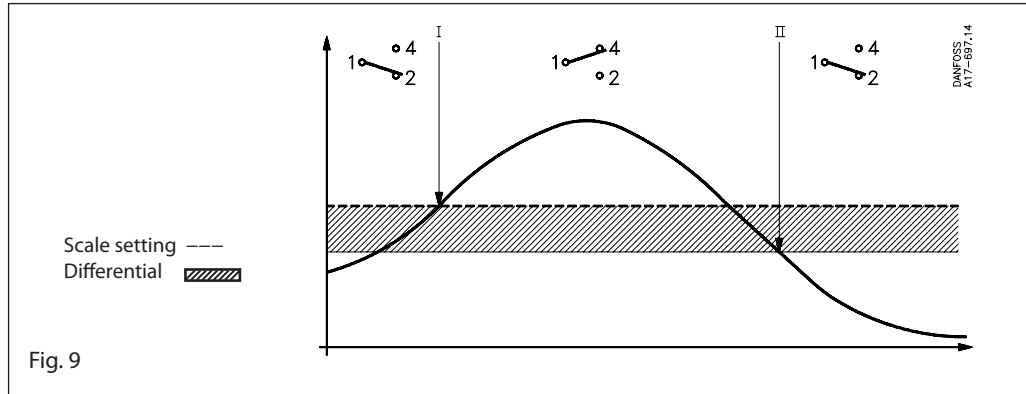

b. RT thermostats with max. reset
 Contacts 1-4 make while contacts 1-2 break when the temperature exceeds the set range value. The contacts changeover to their initial position when the temperature falls to the scale value minus the differential (see fig. 10).

- I. Alarm for rising temperature given at the set value.
 - II. Alarm for falling temperature given at the set value minus the differential.
- Manual reset possible only when the temperature has fallen to the range setting minus differential.

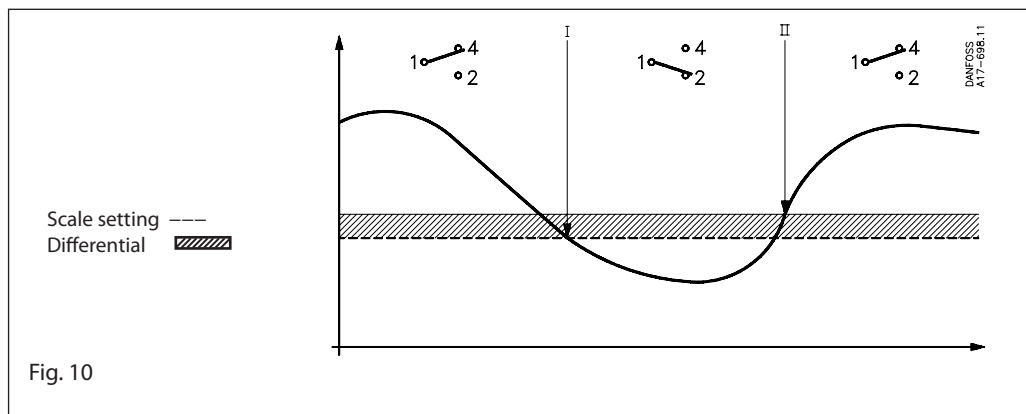

RT units with vapour charge

The method of operation of these units is based on the connection between the pressure and temperature of saturated vapour. The sensor system contains just a small amount of liquid and this is brought completely to vapour form. If the sensor in this type of unit is located coldest in relation to the capillary tube and bellows housing, the ambient temperature has no influence on regulation accuracy.

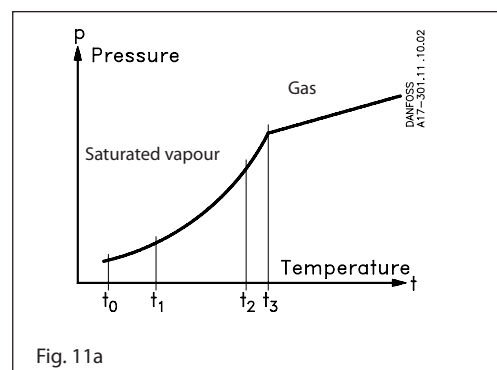

Fig. 11a

RT units with adsorption charge

The thermostatic element contains a superheated gas together with a solid substance (always in the sensor) having a large adsorption surface. This gives an advantage in that the sensor can be installed either colder or warmer than the remaining part of the thermostatic element. However, the charge is to some extent sensitive to changes in the temperature of the bellows and capillary tube.

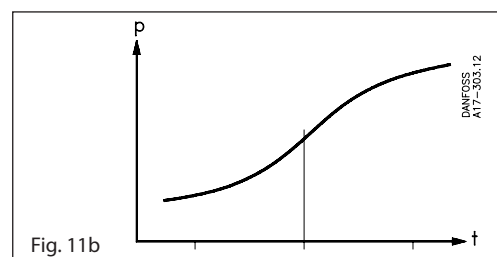

Fig. 11b

Scale correction

If the thermostat is to be used in ambient temperatures that differ significantly from the factory setting (20°C), compensation can be made for the scale deviation:

Scale correction = Z x a

Z can be found from fig. 11c, while a is the correction factor from the table.

Example:

Find the necessary scale correction for a RT 108 with a regulation range +30 to +140°C.

Setting: 85°C

Ambient temperature: 50°C

Correction:

$$\frac{\text{Set value} - \text{min. scale value}}{\text{max. scale value} - \text{min. scale value}} \times 100 = \%$$

$$\frac{85 - 30}{140 - 30} \times 100 = 50\%$$

Correction factor from table 2.0 (a)

Factor for scale deviation (see fig. 11c): + 1.2 (Z)

Scale correction: Z x a = 1.2 x 2.0 = 2.4°C

Corrected setting: 85 + 2.4 = 87.4

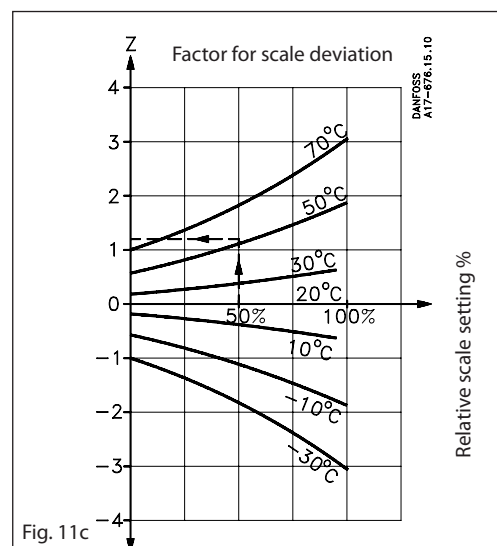

Fig. 11c

Type	Range °C	Correction factor a
RT 2	-25 → 15	2.3
RT 7	-25 → 15	2.9
RT 8/L	-20 → 12	1.7
RT 12	-5 → 10	1.2
RT 14/L	-5 → 20	2.4
RT 15	8 → 32	1.2
RT 23	5 → 22	0.6
RT 101/L	25 → 90	5.0
RT 102	25 → 90	5.0
RT 108	30 → 140	2.0
RT 140/L	15 → 45	3.1

RT units with solid charge

The method of operation of these units is based on the connection between the pressure and temperature of saturated vapour.

The sensor system contains a fairly large amount of liquid, of which only a small part is brought to vapour form. If the sensor in this type of unit is located warmest in relation to the capillary tube and bellows housing, the ambient temperature has no influence on regulation accuracy.

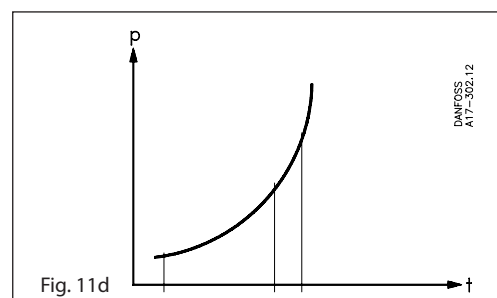
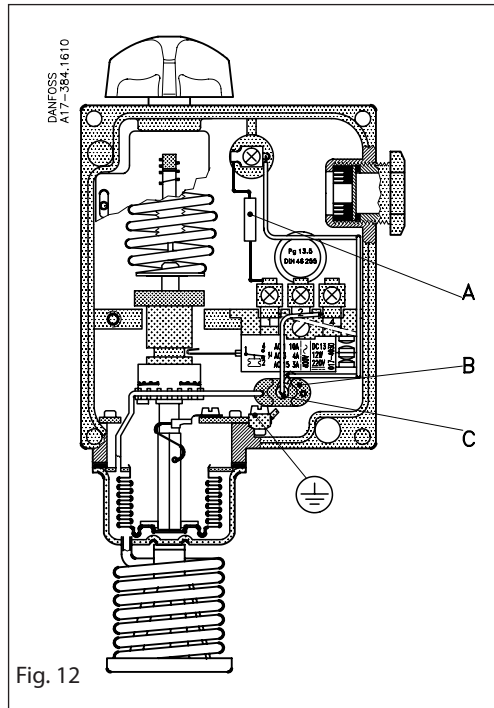

Fig. 11d

RT 115 for control of ventilation plant in livestock buildings



- A. Series resistor
- B. Bulb sensor
- C. Heating element

RT 115 has two sensors, each of which is connected to the space between bellows and bellows housing; see fig. 12. One sensor is a normal, external, rigid coiled capillary tube type, the other is a bulb sensor located in the thermostat housing.

The bulb sensor is heated by an element which is cut in when the thermostat stops the fans and is cut out when the thermostat starts the fans.

The for of operation is as follows:

If the room temperature is more than the value set on the thermostat, 20°C for example, the fans run continuously (100% operating time). If the room temperature falls to 20°C, the switch contacts changeover, the fan stops and the bulb sensor heating element cuts in.

When the bulb sensor is heated up, pressure in the sensor system increases and after a certain time the switch changes over again thereby cutting in the fans and cutting out the element. If the room temperature falls more than 2°C under the set temperature - in this example, lower than 18°C - the fans stop completely. The heating element is cut in as usual but can no longer heat the bulb sensor sufficiently to create the required pressure increase in the thermostatic element to cut in the fans again. Thus with a room temperature of less than 18°C the operating time is 0%.

An example is shown in fig. 13.

With temperature settings other than the one shown, the inclined line in the diagram is displaced parallel. The line break point on the right of the diagram always corresponds to the set value. It is therefore possible to maintain a stable room temperature and at the same time obtain periodic ventilation where the duration of the ventilation periods depends on the difference between the actual room temperature and the set temperature.

By ensuring that the thermostat is always set at least 2°C over the lowest permissible room temperature, the thermostat will never allow the room temperature to fall below the desired level.

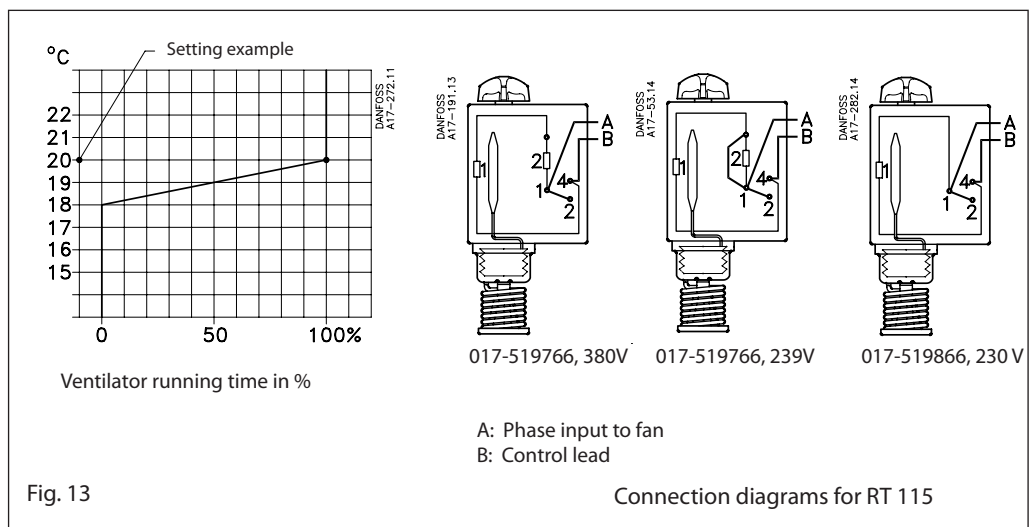

Fig. 13

Connection diagrams for RT 115

Application

RT-L thermostats are fitted with an adjustable neutral zone. This enables the units to be used for floating control. The terminology involved is explained below.

Floating control

A form of discontinuous control where the correcting element (e.g. valve, damper, or similar) moves towards one extreme position at a rate independent of the magnitude of the error when the error exceeds a definite positive and towards the opposite extreme position when the error exceeds a definite negative value.

Hunting

Periodic variations of the controlled variable from the fixed reference.

Neutral zone

The interval in the controlled variable in which the correcting element does not respond.

Mechanical differential

The interval between the values of the controlled variable in which the correcting element does respond.

The contact system in neutral zone units cannot be exchanged, as the contact system adjustment is adjusted to the other parts of the unit.

Neutral zone setting

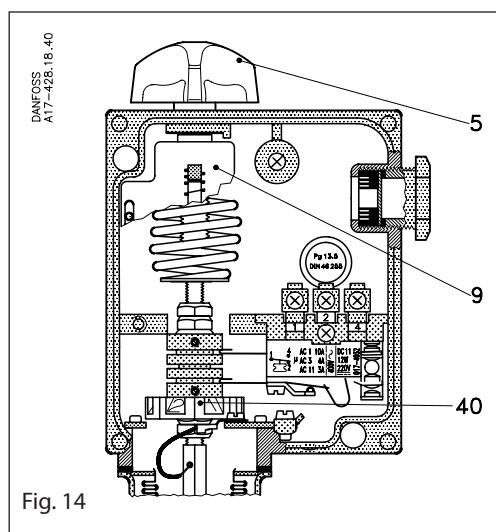

Fig. 14

5. Setting knob

9. Main scale

40. Neutral zone disc with scale

The range is set using the setting knob (5), fig. 14, while reading the main scale (9). The set value is the break temperature for contacts 1-4, fig. 15. The required neutral zone can be found in the diagram for the unit concerned, fig. 16. The position at which the neutral zone disc (40) must be set can be read from the low scale in the diagram.

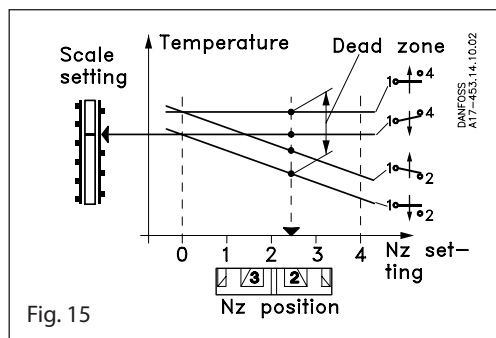

Fig. 15

Example: RT 16L

Setting temperature: +24°C
 Required neutral zone: 1.9°C
 Using the setting knob, set the thermostat on 24°C.

The dotted lines in the diagram for the RT 16L fig. 16 intersect each other on the curve for position 2.8 and the neutral zone setting disc (40) must be set to that position.

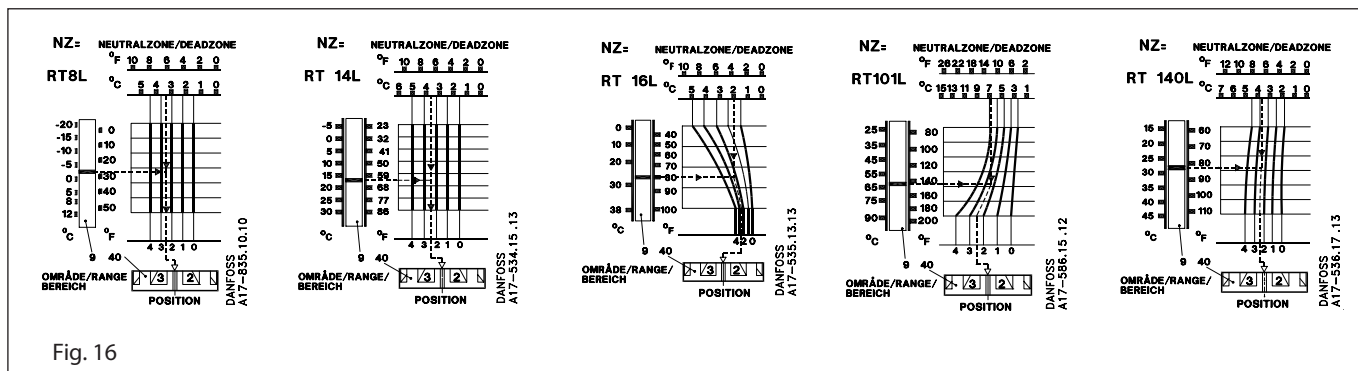

Fig. 16

Application

Control and monitoring of temperature differentials
 An RT differential thermostat is an electric single-pole changeover switch. The position of the switch contacts is controlled by the difference in temperature between the two sensors of the thermostat.
 The RT 270 is used in process plant, ventilation

plant and refrigeration and heating plant, where there is a need to maintain a certain temperature difference, from 0 to 20°C, between two media. One of the sensors is used as a reference, the other as an indirect controlled variable. (The direct controlled variable is the temperature differential).

Setting

- 1. Sensor for the lowest temperature (LT)
- 5. Setting disc
- 9. Scale
- 32. Sensor for the highest temperature (HT)

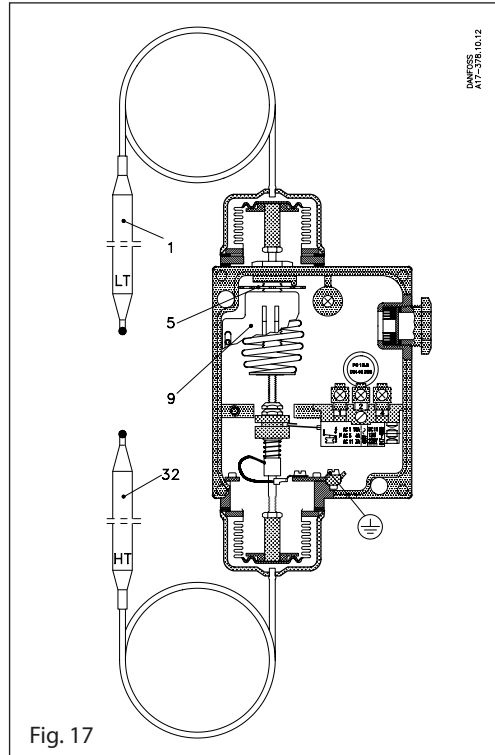

The required temperature differential between the LT sensor (1) (lowest temperature) and the HT sensor (32) (highest temperature) is set using the setting disc (5) while reading the scale (9). Fig. 17 is a cross-sectional drawing of the RT 270. The differential thermostat has two bellows elements: an LT element whose sensor must be placed in the medium with the lowest temperature, and an HT element whose sensor must be placed in the medium with the highest temperature. The main spring has a rectilinear characteristic. Within the differential range it can be set for different temperature differentials by means of the setting disc. When the differential between LT and HT sensor temperatures is reduced, the main spindle moves downwards. The contact arm is moved downwards by the guide bush so that contact 1-4 break and contacts 1-2 make when the set temperature differential is reached. The switch contacts change back when the temperature differential has increased to the set value plus the fixed contact differential of approx. 2°C.

Function

Differential thermostats are fitted with a changeover switch (SPDT)
 When the differential temperature falls below the set value, contacts 1-4 break and contacts 1-2 make. When the differential temperature rises to the set range value plus the fixed contact differential, contacts 1-2 break and contacts 1-4 make.

- I. Contacts make when differential temperature falls below the range scale setting.
- II. Contacts make when differential temperature rises above the range scale plus the fixed contact differential.

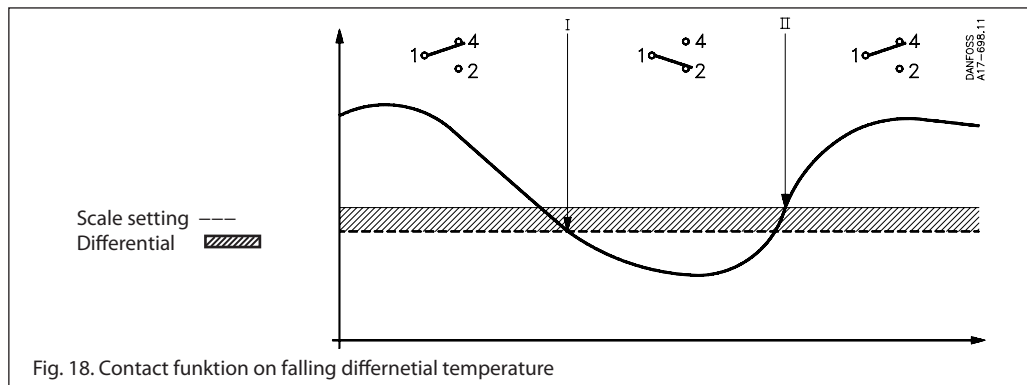

Example
 The temperature rise across an air cooler must be held below 5°C. An alarm must be given when the differential temperature of the cooling water exceeds the 5°C

The choice is an RT 270 with a range of 0-15°C and a fixed contact differential of 2°C.
 Range setting: $5-2^{\circ}\text{C} = 3^{\circ}\text{C}$
 When the differential temperature exceeds the range setting plus the fixed contact differential ($3+2^{\circ}\text{C}$) an alarm will be given.

Spare parts and accessories

Version	Symbol	Description	Contact rating	Code no.
Standard		Single-pole changeover switch (SPDT) with terminal board proof against leakage current Fitted in all standard versions of type RT¹⁾. Snap action changeover contacts.		017-403066
With max. reset		For manual reset of unit after contact changeover on rising pressure For units with max. reset.	<i>Alternating current:</i> AC-1 (ohmic): 10 A, 400 V AC-3 (inductive): 4 A, 400 V AC-14/15 (coil/transformer): 3 A, 400 V Blocked rotor: 28 A, 400 V	017-404266
With min. reset		For manual reset of units after contact changeover on falling pressure. For units with min. reset.	<i>Direct current:</i> DC 13/14: 12 W, 230 V	017-404166
Standard		Single-pole changeover switch (SPDT) with gold plated (oxide-free) contact surfaces. Increases cut-in reliability on alarm and monitoring systems, etc. Snap action changeover contacts. Terminal board proof against leakage current.	<i>Alternating current:</i> AC-1 (ohmic): 10 A, 400 V AC-3 (inductive): 2 A, 400 V AC-14/15 1 A, 400 V Blocked rotor: 14 A, 400 V <i>Direct current:</i> DC-13/14: 12 W, 230 V	017-424066
Cuts in two circuits simultaneously		Single-pole changeover switch that cuts in two circuits simultaneously on rising pressure. Snap action changeover contacts. Terminal board proof against leakage current.	<i>Alternating current:</i> AC-1 (ohmic): 10 A, 400 V AC-3 (inductive): 3 A, 400 V AC-14/15 2 A, 400 V Blocked rotor: 20 A, 400 V	017-403466
Cuts out two circuits simultaneously		Single-pole changeover switch that cuts out two circuits simultaneously on rising pressure. Snap action changeover contacts. Terminal board proof against leakage current.	<i>Direct current:</i> DC-13/14: 12 W, 230 V * If current is led through contacts 2 and 4, i.e. terminals 2 and 4 connected but not 1, max. permissible load is increased to 90 W, 220 V - - -.	017-403666
With non-snap action changeover contacts		Single-pole changeover with non-snap action changeover gold plated (oxide-free) contacts.	<i>Alternating or direct current:</i> 25 VA, 24 V	017-018166

¹⁾ At load types with low currents/voltages contact failure may occur on the silver contacts because of oxidation. In systems where such a contact failure is of great importance (alarm etc.), gold plated contacts are recommended.
Contact systems for neutral zone units are not available as spare parts. Exchange not possible, as the contact system adjustment is adjusted to the other parts of the unit.

The switch contacts are shown in the position they assume on falling temperature, i.e. after downward movement of the RT main spindle.
The setting pointer of the control shows the scale value at which contact changeover occurs on falling temperature. An exception is switch no. **017-403066** with max. reset where the setting pointer shows the scale value at which contact changeover occurs on rising pressure.

Switches

Version	Symbo	Description	Contact rating	Code no.
With min. reset		For manual reset of unit after contact changeover on falling pressure. Gold plated (oxide-free) contact surfaces	<i>For Alarm application</i> <i>Alternating current:</i> AC-1 (ohmic): 10 A, 400 V AC-3 (inductive): 2 A, 400 V Full load current: 2 A, 400 V AC-14/15: 1 A, 400 V Blocked rotor: 14A, 400 V	017-404766
With max. reset		For manual reset of unit after contact changeover on rising pressure. Gold plated (oxide-free) contact surfaces	<i>Direct current</i> DC-13/14: 12W, 230 V <i>For control application</i> max. 100 mA / 30 V a.c./ d.c. min. 1 mA / 5 V a.c. / d.c.	017-404866

Part		Description	Qty.	Code no.
Cover		Covers: Polyamide	5	017-436166
		Colour: Pale grey RAL 7035	5	017-436266
Setting knob		Replacement Pale grey Ral 7035	30	017-436366
Seal cap		Seal cap to replace setting knob so that Setting can only be altered with tools	20	017-436066
Seal screws for cover and seal cap			1 + 1	017-425166
Capillary tube gland		For all RT thermostats with remote sensor. G½A (pipe thread ISO 228/1), oil resistant rubber washer for max. 110°C/90 bar	5	017-422066
Capillary tube gland		For RT 106 thermostats with remote sensor. G¾A (pipe thread ISO 228/1), oil resistant rubber washer for max. 110°C/90 bar	1	003N0155
Sensor clip		For all RT units with remote sensor L = 76 mm	10	017-420366
Heat conductive compound		For RT thermostats with the sensor insert in a pocket. Tube with 3.5cm³ compound to be filled in the sensor pocket to improve heat transfer between pocket and sensor. Application range for compound: -20 to +150°C, momentarily up to 220°C	1	041E0114
Sensor holder		For RT 14, 101 and 270 Sensor holder for wall mounting incl. four capillary tube clips	20 set	017-420166

Sensor pocket for RT thermostats with cylindrical remote sensor

Used for the following types		Insertion length L mm	d mm	Material	Connection pipe thread ISO 228/1	Code no.
All except RT 12, 23, 106, 108, 124, 270		112	11	Brass	G ½A	017-437066
All except RT 12, 23, 106, 108, 124, 271		112	11	Stainless steel 18/8		017-436966
RT 106, RT 124 ²⁾		110	15	Brass		060L327166 ¹⁾
RT 106, RT 124 ²⁾		110	15	Stainless steel 18/8		060L326866 ¹⁾
RT 106, RT 124 ²⁾		160	15	Brass		060L326366 ¹⁾
RT 106, RT 124 ²⁾		160	15	Stainless steel 18(8)		060L326966 ¹⁾
RT 271		182	11	Brass		017-436766
RT 108		465	11	Brass		017-421666

¹⁾ Supplied without washer set

²⁾ Unit supplied with washere set

See possibly page 8.